

The Woodlands

At Barrett Hill

DEDICATION AND ACKNOWLEDGEMENT:

WE, THE UNDERSIGNED JOHN PELLEGRINI AND JULIA PELLEGRINI, THE OWNERS OF THE REAL ESTATE SHOWN, HEREBY CERTIFY THAT WE HAVE CAUSED THE SAME TO BE SURVEYED AND PLATTED INTO LOTS, COMMON AREAS, AND ROADWAYS AS SHOWN, AND THAT SAID LOTS ARE NUMBERED 1 TO 14, INCLUSIVE, AND THAT THE LANE OR ROADWAY THROUGH SAID SUBDIVISION, AS DEPICTED, INCLUDING A TURN-AROUND, IS HEREBY DEDICATED TO THE PUBLIC FOR USE AS SUCH.

THIS SUBDIVISION AND PLAT ARE SUBJECT TO A DECLARATION OF RESTRICTIONS AND COVENANTS OF THE WOODLANDS AT BARRETT HILL FILLED IN THE OFFICIAL RECORD VOLUME 101, PAGE 889, GUERNSEY COUNTY, OHIO, GUERNSEY COUNTY RECORDER'S OFFICE, TOGETHER WITH ANY FURTHER AMENDMENTS OR MODIFICATIONS THERETO, AND SUCH COVENANTS, CONDITIONS, AND RESTRICTIONS SHALL RUN WITH THE LAND. SAID RESTRICTIONS, COVENANTS, AND CONDITIONS WHICH RUN WITH THE LAND SHALL APPLY WHETHER OR NOT SPECIFIED IN SUBSEQUENT CONVEYANCES.

WE FURTHER CERTIFY THAT THERE ARE NO UNPAID TAXES OR SPECIAL ASSESSMENTS AGAINST THE LAND CONTAINED IN THIS PLAT.

Stephen C. Heine
WITNESS

John Pellegrini
JOHN PELLEGRINI
DECLARANT AND DEVELOPER

Linda S. Hill
WITNESS

Julia Pellegrini
JULIA PELLEGRINI, WIFE OF JOHN PELLEGRINI

STATE OF OHIO, COUNTY OF GUERNSEY/SS:

BEFORE ME, A NOTARY PUBLIC IN AND FOR SAID COUNTY, PERSONALLY APPEARED JOHN PELLEGRINI AND JULIA PELLEGRINI, HUSBAND AND WIFE, WHO EXECUTED THE FOREGOING INSTRUMENT AND ACKNOWLEDGED THAT THEY DID SIGN THE SAME, AND THAT IT WAS THEIR FREE ACT AND DEED.

IN TESTIMONY WHEREOF, I HERETO SUBSCRIBE MY NAME AND AFFIX MY OFFICIAL SEAL AT CAMBRIDGE, OHIO, THIS 22 DAY OF November, 1994.

Stephen C. Heine
NOTARY PUBLIC
MY COMMISSION EXPIRES: _____
STEPHEN C. HEINE, Attorney at Law
Notary Public - State of Ohio
My Commission Has No Expiration Date
Section 147.03 R.C.

APPROVED THIS 2 DAY OF November, 1994, GUERNSEY COUNTY DISTRICT BOARD OF HEALTH.

11-21-94
DATE

[Signature]
LARRY CALDWELL, PRESIDENT

CAMBRIDGE SAVINGS BANK, FIRST MORTGAGE HOLDER AND MORTGAGEE ON THE LANDS SET FORTH HEREIN, CONSENT TO THIS PLAT OF LANDS.

2/16/95
DATE

[Signature]
LARRY CALDWELL, PRESIDENT

APPROVED THIS 21st DAY OF November, 1994.

11/21/94
DATE

[Signature]
GLEN SMITH, GUERNSEY COUNTY ENGINEER

TRANSFERRED THIS 21 DAY OF November, 1994.

11/21/94
DATE

[Signature]
GUERNSEY COUNTY AUDITOR

ACCEPTED AND APPROVED UNDER THE OHIO REVISED CODE 711.08 IN THAT AT LEAST MINIMUM SPECIFICATIONS FOR SUBDIVISION THOROUGHFARES AND DRAINAGE MUST BE MET BEFORE APPLICATION UNDER OHIO REVISED CODE SECTION 711.091 IS MADE.

11/21/94
DATE
11-21-94
DATE
11-21-94
DATE

BOARD OF COUNTY COMMISSIONERS,
GUERNSEY COUNTY, OHIO
[Signature]
COMMISSIONER
[Signature]
COMMISSIONER
[Signature]
COMMISSIONER

FILED FOR RECORD THIS 21st DAY OF February, 1995, AT 9:53 O'CLOCK A.M., RECORDED IN THE FOLLOWING PLAT BOOK:

CABINET 3, SLIDE 445

2/21/95
DATE

[Signature]
BETTY J. DODD,
GUERNSEY COUNTY RECORDER

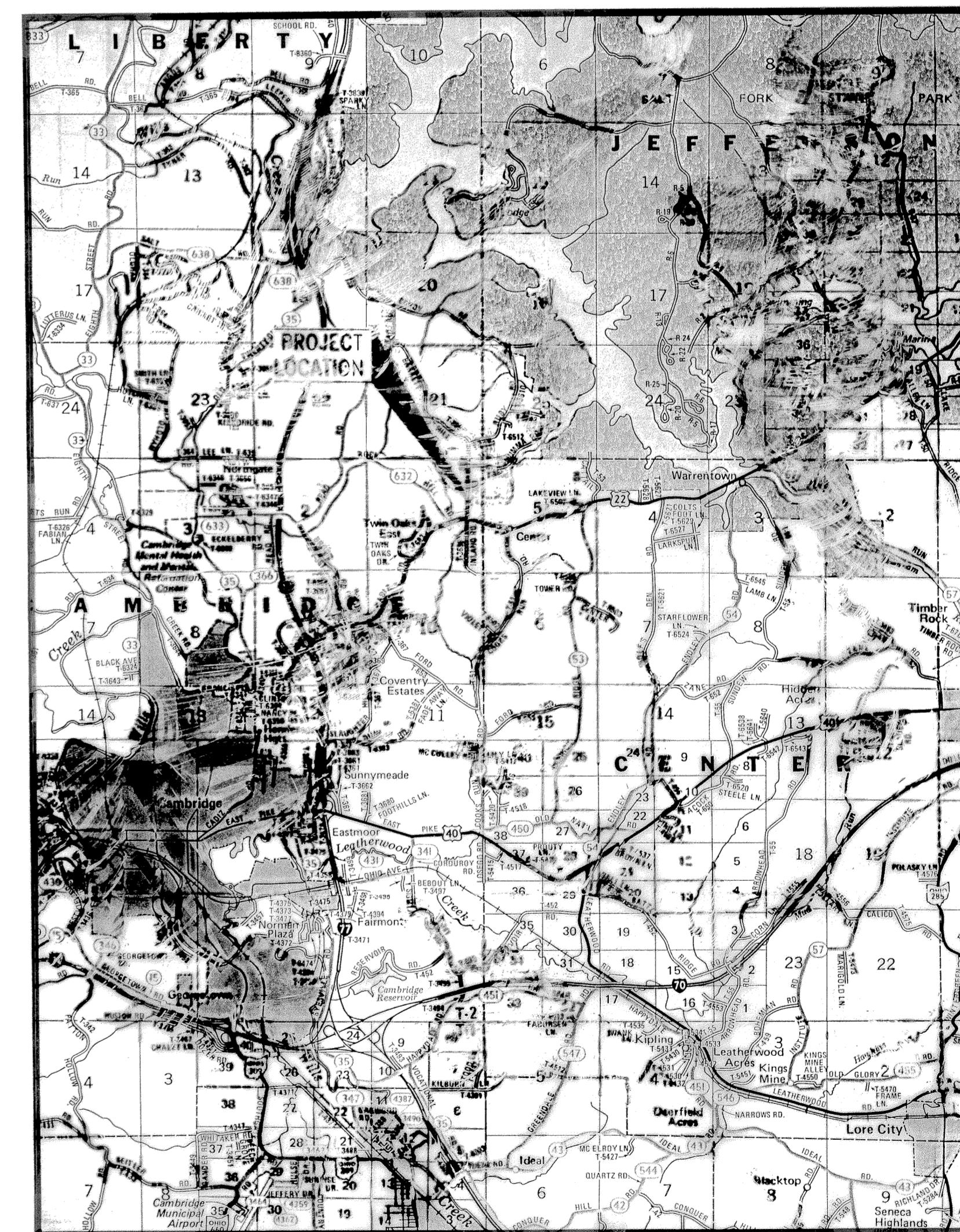

SITE LOCATION MAP
LOCATED IN GUERNSEY COUNTY, OHIO
CAMBRIDGE TOWNSHIP / CENTER TOWNSHIP

DRAFTING BY:
Micro-Computer Design Services
204 Watson Avenue
Cambridge, Ohio 43725
614-432-3864

THIS DRAWING IS NOT TO BE SCALED FOR THE PURPOSE OF CONSTRUCTION OR FABRICATION. DIMENSIONS PROVIDED ON THE DRAWING SHOULD BE USED DURING CONSTRUCTION OR FABRICATION.

THE WOODLANDS
AT BARRETT HILL
CAMBRIDGE, OHIO 43725
PROPERTY & LOT PLANS
COVER SHEET

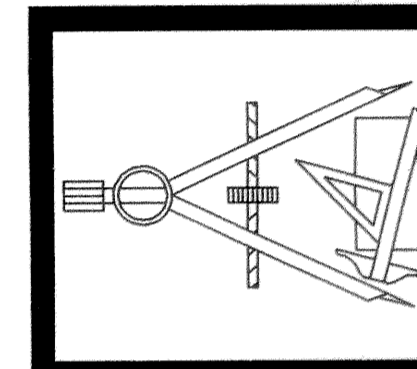

Spiker Surveying
744 1/2 SOUTH 9TH STREET
CAMBRIDGE, OHIO 43725
(614) 439-2057

JOSEPH T. SPIKER, P.S.

DRAWN
G. DIMENT
DATE
OCTOBER 24, 1994
SCALE
AS SHOWN
JOB NO.
007-001

1
1 OF 2 SHEETS

62744
GUERNSEY CO. RECORD OF C.R.
VOL. 101 PAGE 889
95 FEB 21 AM 9:53
RECORDED FEB 22 1995
BETTY J. DODD
RECORDER 43 25 PD